

Q340

User manual

Please read it carefully and keep it properly.

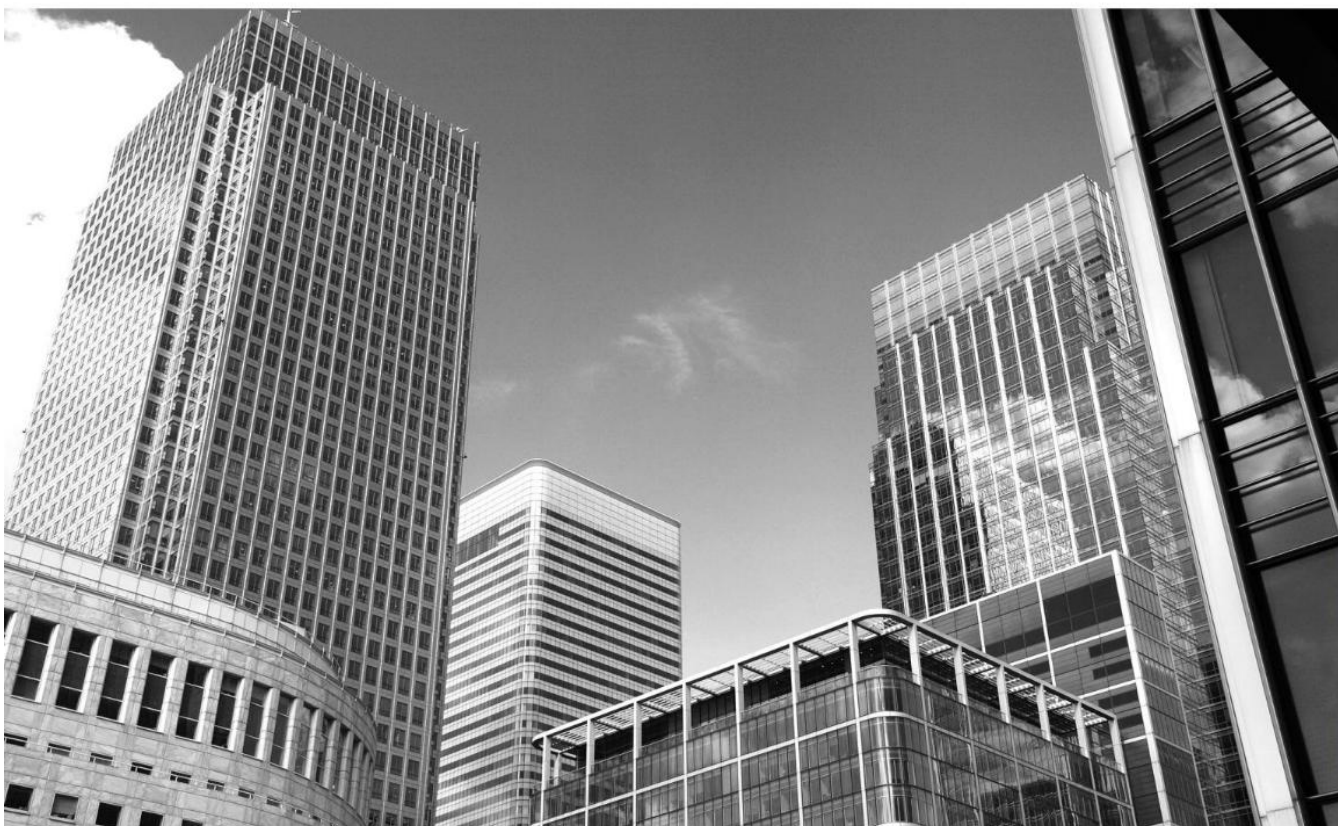

Fast recognition



Various output interface



Suitable for kiosk, turnstiles etc

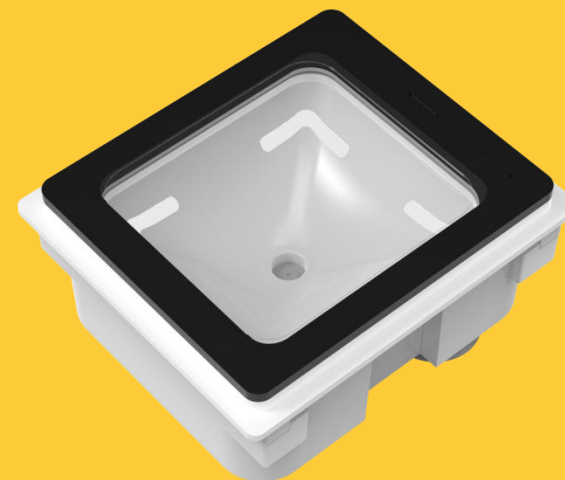

Disclaimer

Before using the product, please read all the contents in this Product Manual carefully to ensure the safe and effective use of the product. Do not disassemble the product or tear up the seal on the device by yourself, or Beijing Vguang Internet Technology Co., Ltd. will not be responsible for the warranty or replacement of the product.

The pictures in this manual are for reference only. If any individual pictures do not match the actual product, the actual product shall prevail. For the upgrade and update of this product, Beijing Vguang Internet Technology Co., Ltd. reserves the right to modify the document at any time without notice.

Use of this product is at the user's own risk. To the maximum extent permitted by applicable law, damages and risks arising from the use or inability to use this product, including but not limited to direct or indirect personal damage, loss of commercial profits, Beijing vguang Internet Technology Co., Ltd. will not bear any responsibility for trade interruption, loss of business information or any other economic loss.

All rights of interpretation and modification of this manual belong to Beijing Vguang Internet Technology Co.,Ltd.

Edit history

Change date	Version	Description	Responsible
2021. 5. 2	V1. 0	Initial version	

Catalog

Disclaimer

Disclaimer	2
1. Preface	5
1.1. Product introduction	5
1.2. Product feature	5
2. Product appearance	6
2.1.1. OVERALL INTRODUCTION	6
2.1.2. PRODUCT SIZE	7
3. Parameters	8
3.1. General parameter	8
3.2. Reading parameter	9
3.3. Electric parameters	10
3.4. Working environment	10
4. Device configuration	11
5. Common Configuration Codes	15
5.1. Working Mode Configuration	15
5.2. Output Mode Configuration	15
5.3. Enter Wrap	17
5.4. 232/485 Baud rate setting	18
5.5. TTL Baud rate setting	20
5.6. Develop protocol pattern configuration	22
5.7. Code system configuration	22
5.8. Scan mode	23
5.9. Action	24
5.10. Switch of swiping card function	26
5.11. Output format of the swipe card	26
5.12. The reverse order of the swipe card	27
5.13. Action after swiping card	28
6. Mounting method	30
7. Attention	31
8. Contact info	32

1. Preface

Thanks for using the Q340 QR code reader, Reading this manual carefully can help you understand the function and features of this device, and quickly master the use and installation of the device.

1.1. Product introduction

Q340 QR code reader was a specially designed embedded type device, which has various output interface, including USB, RS232, RS485, TTL, Wiegand, waterproof level is IP67, suitable for vending machines, turnstiles.

1.2. Product feature

- 1, Scan code& swipe card all in one.
- 2, Fast recognition speed, high accuracy, 0.1 second the fastest.
- 3, Easy to operate, humanized configuration tool, more convenient to config the reader.
- 4, Waterproof level is IP67.

2. Product appearance

2.1.1. OVERALL INTRODUCTION

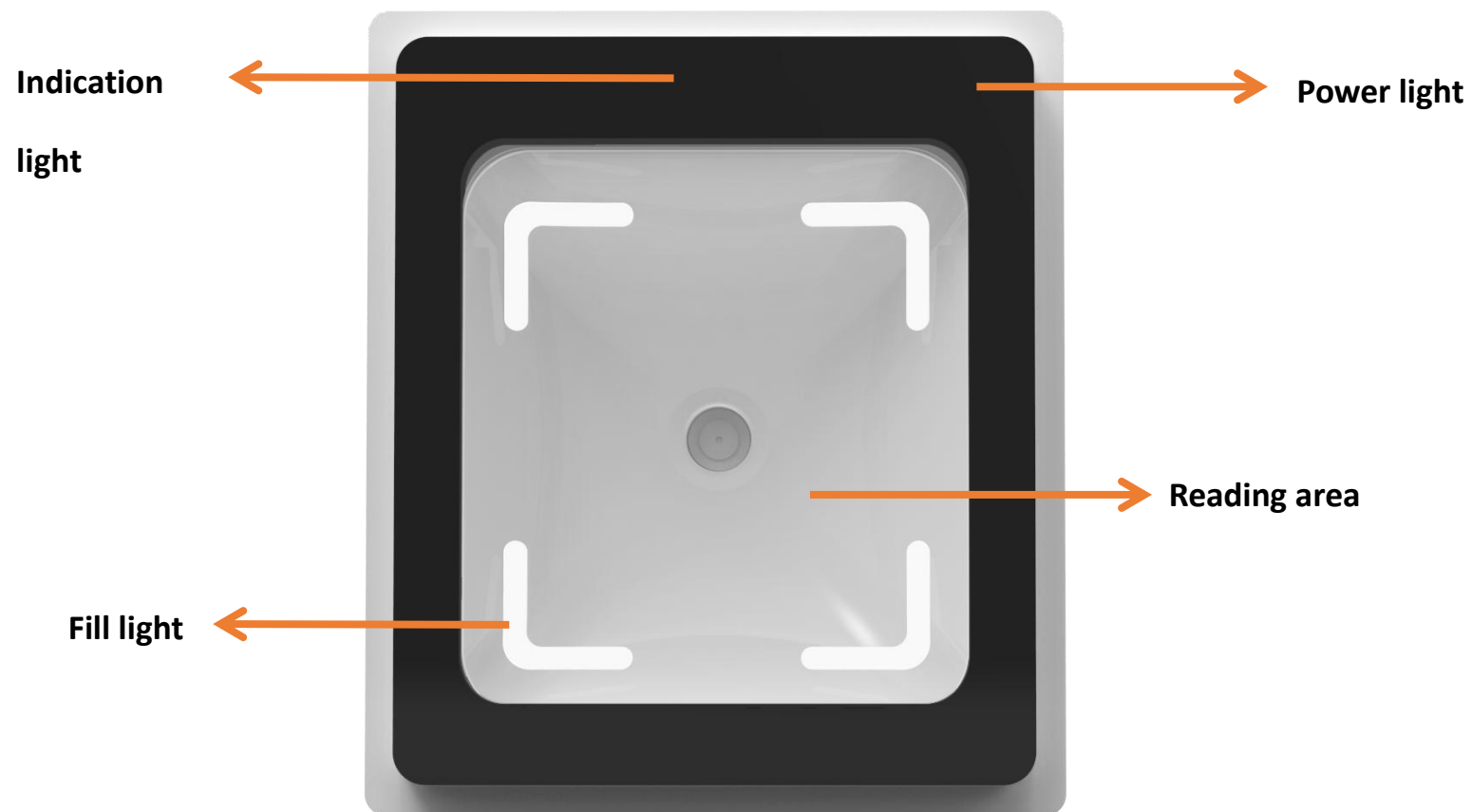

2.1.2. PRODUCT SIZE

Unit: millimeter
(mm)

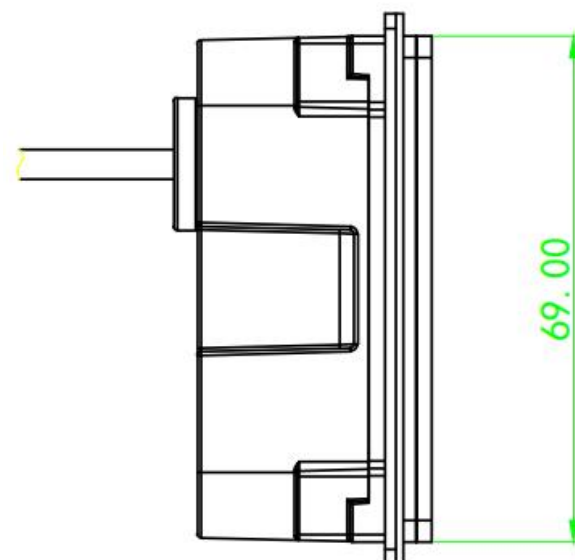
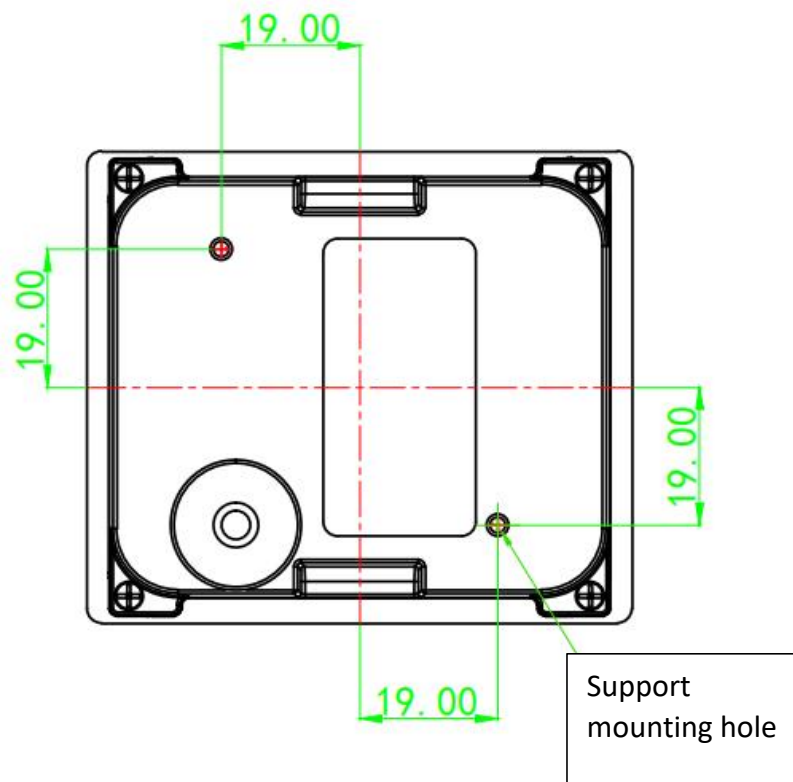
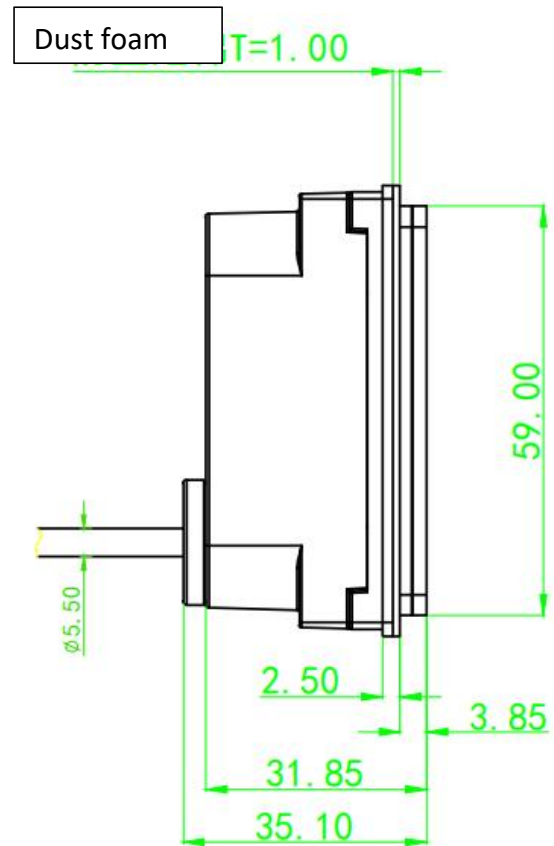
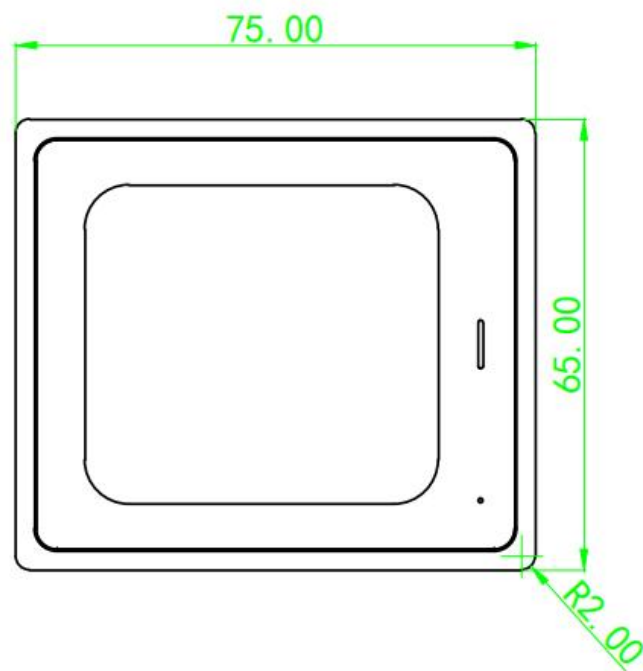

Tapping screw

3. Parameters

3.1. General parameter

General parameter	
Output interface	USB、RS232、RS485、TTL、Wiegand
Indicating method	Red, green light indicator Beeper
Imaging sensor	300,000 pixel CMOS sensor
Max resolution	640*480
Mounting method	Embedded mounting
Size	75mm*65mm*35.10mm
Reading window size	51mm*46mm

3.2. Reading parameter

QR code recognition parameter	
Symbologies	QR、PDF417、CODE39、CODE93、CODE128、ISBN10、ITF、EAN13、DATABAR、aztec etc.
Supported decoding	Both Mobile QR code and printed QR code
DOF	0mm~62.4mm(QRCODE 15mil)
Reading accuracy	≥8mil
Reading speed	100ms per time(average), support reading continuously
Reading direction	tilt±56.3° rotation±360° deflection±55.7° (15milQR)
FOV	Horizontal Field72.1 ° Vertical field 56.6 ° filed angle 84.3 ° (15milQR)
RFID reading parameter	
Supported cards	ISO 14443A, ISO 14443B protocol cards
Reading method	Read UID
Working frequency	13.56MHz
Distance	<5cm

3.3. Electric parameters

The power input can be provided only when the device is connected properly. If the device is plugged or unplugged while the cable is live (hot plugging), its electronic components will be damaged. Make sure that the power is turned off when plugging and unplugging the cable. Poor power supply, too short interval power off and on operation may cause the device cannot work in a stable and normal status. It is necessary to keep the power input stable. After turning off the power input, it need to takes more than 2 seconds to turn on the power input again.。

Electric parameter	
Working voltage	DC 5V-24V
Working current	280mA (5V typical value)
Power consumption	1400mW (5V typical value)

3.4. Working environment

Work environment parameter	
ESD protection	$\pm 8\text{kV}$ (Air discharge) , $\pm 4\text{kV}$ (Contact discharge)
Working temp	-20°C - 65°C
Storage temp	-40°C - 80°C
RH	5%-95% (No condensation) (environment temperature 30°C)
Ambient light	0-100000Lux(Non direct sunlight)

4. Device configuration

Use the Vguang config tool to configure the device. Config the device as the step shows, the example are showing 485 version reader.



5.1 config tool

Step 1, Select the model number Q300.

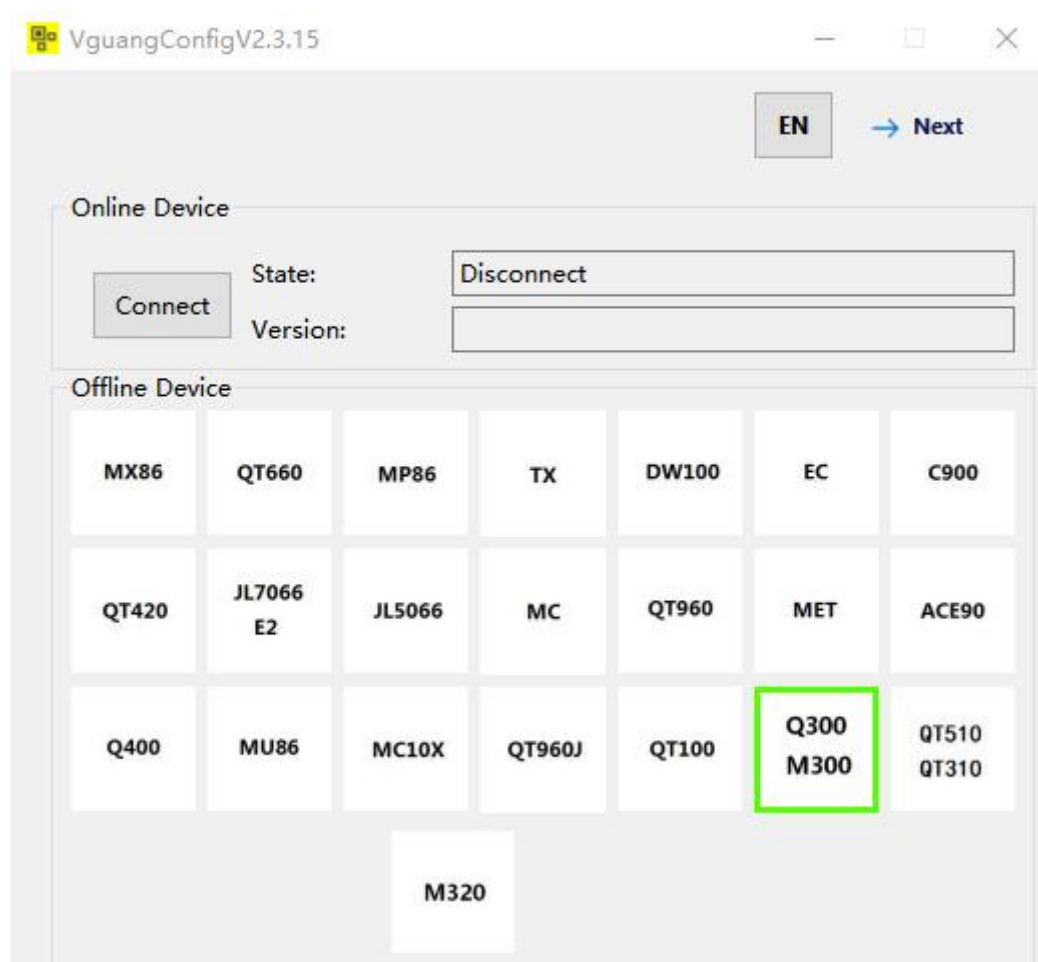

Step 2, Select the output interface, and config the corresponding serial parameters.

The screenshot shows the VguangConfigV2.3.15 software interface. At the top, there is a title bar with the application name and standard window controls. Below the title bar, there is a 'Set Password:' field containing the text '1234567887654321'. To the right of this field are two buttons: 'Next' and 'Main'. Below the password field is a 'Work mode' section with two radio buttons: 'Ordinary' (selected) and 'Develop'. Below the work mode section is an 'Output' section with four radio buttons: 'Keyboard' (selected), 'RS485/232', 'TTL', and 'Wigan'. Below the output section is a 'Development mode' section with two radio buttons: 'Protocol' (selected) and '485 one more'. A note next to the '485 one more' option reads: 'Note: it takes effect under the development r'.

Step 3, Config as your needs

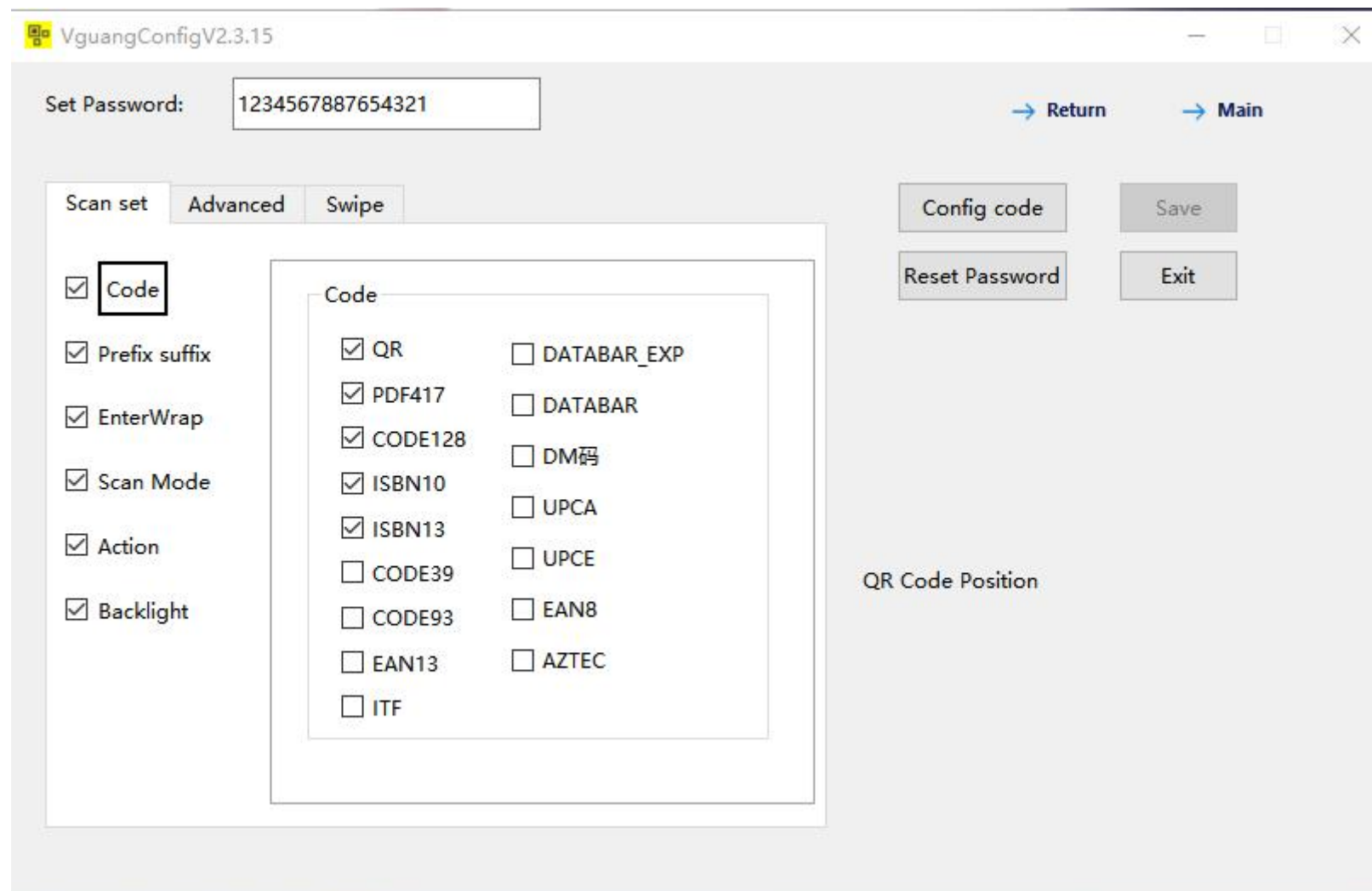

Step 4, After configing as your needs, click “config code”

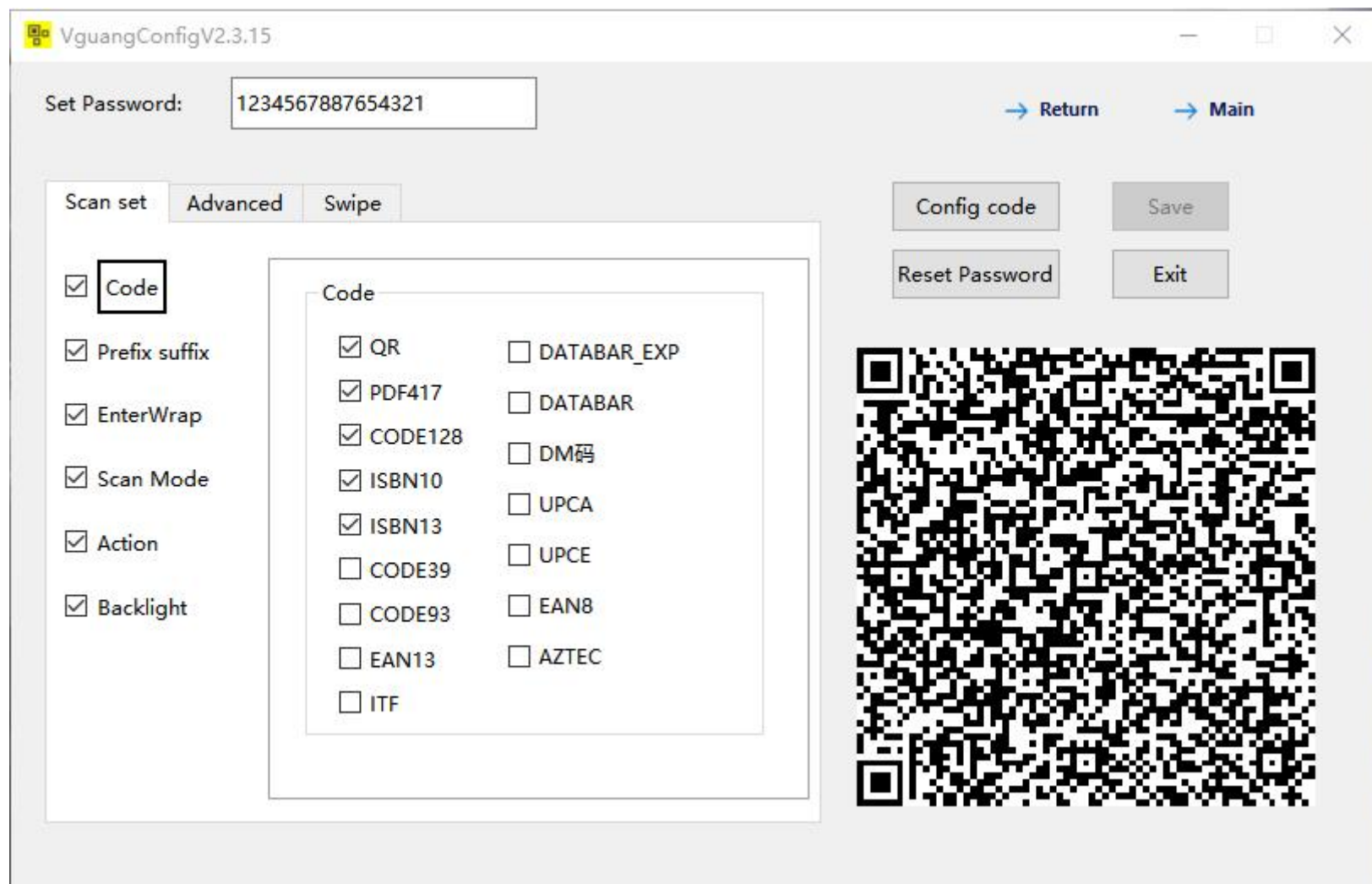

Step 5, Use the scanner to scan the configurations QR code generated by the tool, then restart the reader to finish the new configurations.

For more details about configurations, please refer to the “Vguang configuration tool user manual”.

5. Common Configuration Codes

5.1. Working Mode Configuration



5.2. Output Mode Configuration





5.3. Enter Wrap



Add a carriage return



Cancel the enter



Add a line break



Cancel a newline

5.4. 232/485 Baud rate setting





5.5. TTL Baud rate setting





9600-8-n-1



4800-8-n-1



2400-8-n-1



300-8-n-1

5.6. Develop protocol pattern configuration



5.7. Code system configuration



5.8. Scan mode





5.9. Action





5.10. Switch of swiping card function



5.11. Output format of the swipe card





5.12. The reverse order of the swipe card





Normal card reverse order



Id card reverse order

5.13. Action after swiping card



Buzzer



White light



6. Mounting method

The product using CMOS image sensor, the recognition window should avoid direct sun or other strong light source when install the scanner. The strong light source will cause the contrast in the image too big to decoding, the long term exposure will damage the sensor and cause the device failure.

The recognition window are using tempered glass, which has good transmission of the light, and also a good pressure resistance, but still need to avoid scratching the glass by some hard object, it will affect the QR code recognition performance.

The RFID antenna was in the underside of the recognition window, there should have no metal or magnetic material within 10cm when installing the scanner, or it will affect the card reading performance.

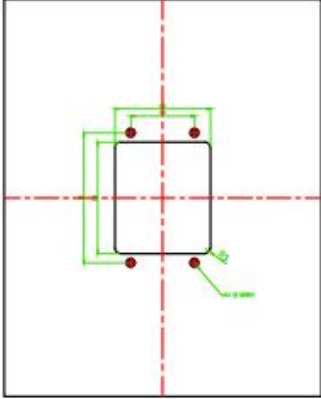
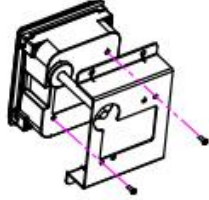
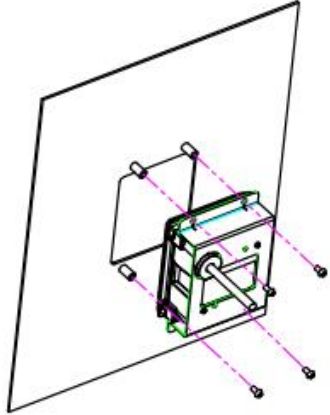
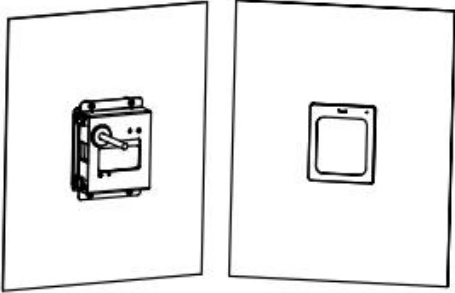
			
<p>Step 1: Open a hole in the mounting plate.</p>	<p>Step 2: Assemble the reader with the holder, and tighten the screws, then plug the cable.</p>	<p>Step 3: assemble the holder with the mounting plate, then tighten the screws.</p>	<p>Step 4, installation finished.</p>

7. Attention

- 1, The equipment standard is 5-24V power supply, it can get power from the access control power or power it separately. Excessive voltage may cause the device fail to work normally or even damage the device.
- 2, Do not disassemble the scanner without permission, otherwise the device may be damaged.
- 3, The installation position of the scanner should avoid direct sunlight. Otherwise, the scanning effect may be affected. The panel of the scanner must be clean, otherwise it may affect the normal image capture of the scanner. The metal around the scanner may interfere with the RFID magnetic field and affect card reading.
- 4, The wiring connection of the scanner must be firm. In addition, ensure the insulation between the lines to prevent the equipment from being damaged by a short circuit.

8. Contact info

Company name: Beijing Vguang Internet Technology Co., Ltd.,.

Address: China Meteorological Science and Technology Park, No.2, Zhenxing Road, Changping District, Beijing, China.

Hot line: 400-810-2019